

LA8 AMPLIFIED CONTROLLER
MAINTENANCE MANUAL – LEVEL 1
VERSION 2.0

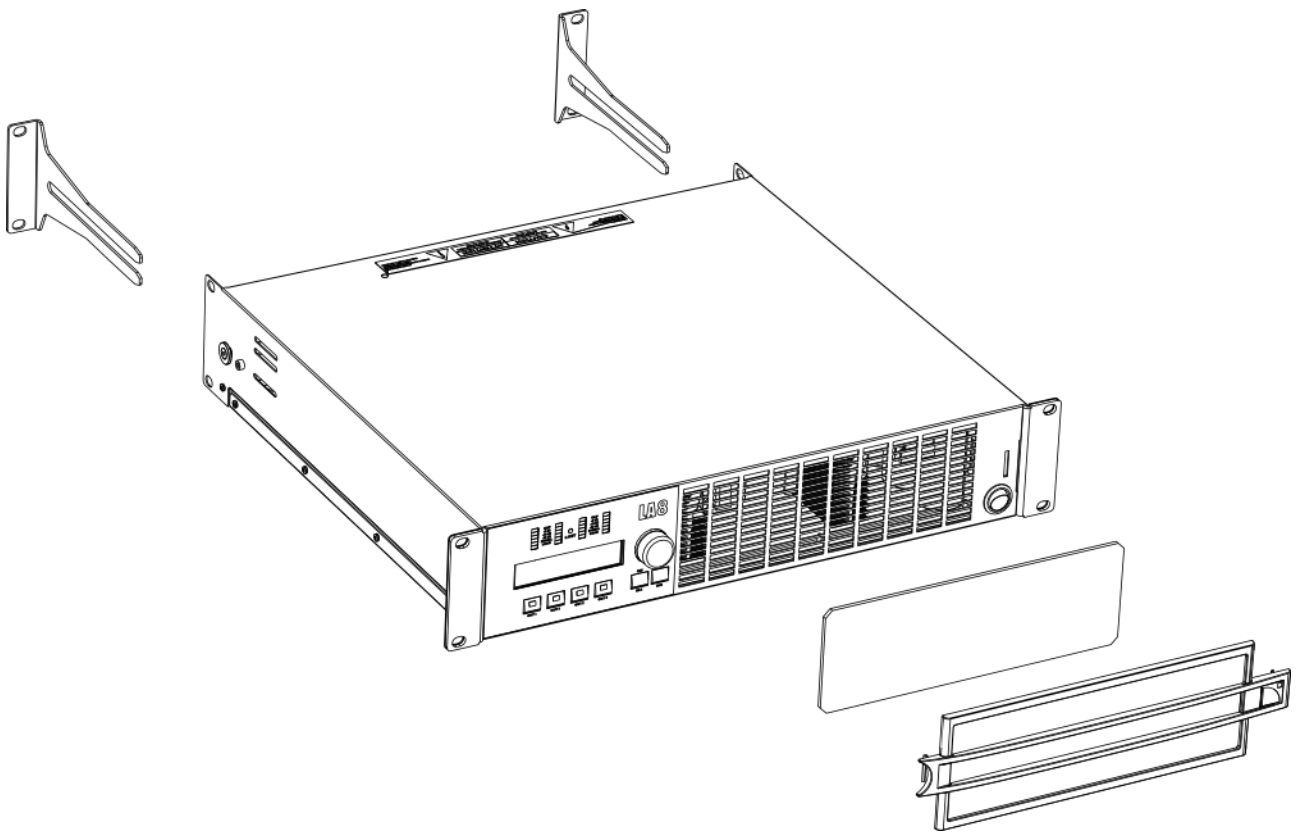

SAFETY INSTRUCTIONS

1. **Read this document.**
2. **Read all SAFETY INSTRUCTIONS carefully as well as DANGER and OBLIGATION warnings.**
3. **Never incorporate equipment or accessories not approved by L-ACOUSTICS®.**
4. **Strictly follow the sequence of the successive steps in all procedures.**
5. **Never use a faulty apparatus.**
An apparatus showing any sign of issue must immediately be put aside and withdrawn from use.
6. **Never attempt to perform a maintenance operation not mentioned in this manual.**
This manual contains the maintenance operations authorized for the End User (level 1).
Performing another operation will expose the user to hazardous situations.
Contact L-ACOUSTICS® for advanced maintenance.
7. **Follow all legally prescribed instructions if sending an apparatus to L-ACOUSTICS® for maintenance.**
Save all user presets to files using LA NETWORK MANAGER software.

SYMBOLS

The following symbols are used in this document:



DANGER

This symbol indicates a potential risk of harm to an individual or damage to the product.
It can also notify the user about instructions that must be strictly followed to ensure safe installation or operation of the product.



ELECTRICAL HAZARD

This symbol indicates a potential risk of electrical injury.
It can also notify the user about instructions that must be strictly followed to ensure safe installation or operation of the product.



OBLIGATION

This symbol notifies the user about instructions that must be strictly followed to ensure proper installation or operation of the product.



EQUIPMENT

This symbol indicates the equipment, tools, and spare parts required to perform a procedure.



INFORMATION

This symbol notifies the user about complementary information or optional instructions.

CONTENTS

REVISION HISTORY	4
GLOSSARY	4
INTRODUCTION	4
1 EQUIPMENT AND TOOLS	5
2 QUALITY CONTROL	6
3 DIAGNOSIS	7
Diagnosis table	7
Exploded view	15
Working time	15
4 MAINTENANCE PROCEDURES	16
D/R 001 – FRONT FRAME	16
D/R 002 – FOAM FILTER	17
D/R 003 – Power plug	18
D/R 004 – REAR BRACKETS	19
APPENDIX: KR LIST	20

REVISION HISTORY

Document identification	Distribution date	Modifications
LA8_MMI_EN_1.0	June 11 th , 2013	Initial version
LA8_MMI_EN_2.0	June 10, 2014	Updated for firmware V. 2.1.3.3

GLOSSARY

CE	Europe
CN	China
D/R	disassembly/reassembly
KR	Replacement Kit
JP	Japan
LA NWM	LA NETWORK MANAGER remote control software
LA8	in a general context: amplified controller of LA8 type when used along with LA8CN, LA8JP or LA8US: LA8 CE version
LA8CN	LA8 CN version
LA8JP	LA8 JP version
LA8US	LA8 US version
MODULE	part of an amplified controller, written in uppercase characters
SMPS	Switched Mode Power Supply (power supply inside of the controller)
US	United States

INTRODUCTION

This **LA8 maintenance manual – level 1** is intended for **End Users** and gathers the **level 1 procedures** for the **LA8 amplified controller** (periodic maintenance, troubleshooting and disassembly/reassembly of outside **MODULES**).

It is intended to be used as follows:

1. Perform the **QUALITY CONTROL** procedure and note down all detected issues.
2. Refer to the **DIAGNOSIS TABLE** and **EXPLODED VIEW** for indications on how to address these issues.
3. Perform the indicated corrective actions using the corresponding **MAINTENANCE PROCEDURES**.
4. Perform the **QUALITY CONTROL** procedure a new time to verify there are no remaining issues.

1 EQUIPMENT AND TOOLS

The following table is the complete list of equipment and tools required to perform **all level I maintenance procedures** on the **LA8 amplified controller**.

Equipment and tools	Reference	Manufacturer
audio source with a known musical program	—	—
CAT5e U/FTP cable	—	—
ear protections	—	—
voltage absence tester	—	—
wire stripping pliers	793936	Facom
full range loudspeaker	—	L-ACOUSTICS
LA NWM	—	L-ACOUSTICS
subwoofer	—	L-ACOUSTICS
Stanley knife	0-10-018	Stanley

2 QUALITY CONTROL

This procedure must be performed for periodic maintenance and to detect possible issues on a controller.

Tools



Name	Reference	Distributor
audio source with a known musical program	—	—
LA NWM	—	L-ACOUSTICS
CAT5e U/FTP cable	—	—
full range loudspeaker	—	L-ACOUSTICS
subwoofer	—	L-ACOUSTICS
ear protections	—	—

Procedure

1. Inspect the external structure of the controller for any lost or damaged part.
2. To verify if the controller is clean, follow these steps:
 - a. Disassemble the FRONT FRAME and the FOAM FILTER, see procedure **D/R 001**.
 - b. Verify if the FOAM FILTER is clean.
 - c. Look inside the controller through the front grill (do not touch any part) and verify if the inside is clean.
 - d. Reassemble the FRONT FRAME and the FOAM FILTER, see procedure **D/R 001**.
3. Plug the controller to mains and power it on.
Verify if the LCD screen and all LED lit during the start-up sequence.
4. To verify if the network functionalities of the controller work, follow these steps:
 - a. Connect the controller to an Ethernet port of the computer hosting LA NWM.
Use the CAT5e U/FTP cable.
 - b. Launch LA NWM.
 - c. Verify if the controller can be put in **online mode** (refer to the **LA NWM video tutorial**).
5. Verify if the latest version of firmware is installed (see the **LA8 user manual** or the **LA NWM video tutorial**).
If not, update firmware from LA NWM.
6. Select a known preset and verify if the indications displayed on screen are in accordance with it.
7. To verify sound presence and quality on each output channel follow these steps:
 - a. Plug the audio source to an input connector of the controller (IN A or IN B).
 - b. Plug the full range loudspeaker to output connector OUT1.
 - c. Select a corresponding preset.
 - d. Select the routing from the audio source to OUT1.
 - e. Play the musical program.
 - f. Set the OUT1 gain to -40 dB.
 - g. Unmute OUT1.
 - h. Set the OUT1 gain to obtain a medium sound level.
 - i. Verify if the sound is clear and undistorted.
 - j. Mute OUT1.
 - k. Repeat these steps for OUT2, OUT3 and OUT4.



There is a risk of ear damage due to high sound level.

Use ear protections.

8. To verify the power capability of each output channel follow these steps:
 - a. Plug the audio source to an input connector of the controller (IN A or IN B).
 - b. Plug the subwoofer to output connector OUT1.
 - c. Select a corresponding preset.
 - d. Select the routing from the audio source to OUT1.
 - e. Play the musical program.
 - f. Set the OUT1 gain to -40 dB.
 - g. Unmute OUT1.
 - h. Set the OUT1 gain to obtain a high sound level.
 - i. Verify if the sound remains clear and undistorted up to the limit level.
 - j. Mute OUT1.
 - k. Repeat these steps for OUT2, OUT3 and OUT4.

3 DIAGNOSIS

Diagnosis table

For any **issue**, follow the check sequence in the **possible causes** column.

At each step, apply the **inspection procedure** (if exists) and consider the resulting **diagnosis**.

See also the **EXPLODED VIEW** to obtain an overview of the **disassembly/reassembly procedures**.

External structure		
Issue	Possible causes	Inspection procedure / Diagnosis
FOAM FILTER clogged	operation in very dusty or cracked-oil smoke machine environments	Clean the FOAM FILTER, see procedure D/R 002 .
Inside of the controller dirty (visible from the front grill)	operation in very dusty or cracked-oil smoke machine environments	Contact L-ACOUSTICS®.
FOAM FILTER lost or damaged	mechanical shock	Replace the FOAM FILTER, see procedure D/R 002 .
FRONT FRAME lost or damaged	mechanical shock	Replace the FRONT FRAME, see procedure D/R 001 .
REAR BRACKETS lost or damaged	mechanical shock	Replace the REAR BRACKETS, see procedure D/R 004 .
CHASSIS damaged	mechanical shock	Contact L-ACOUSTICS®.
POWER CORD damaged	pulled, trampled, pinched, frayed...	Contact L-ACOUSTICS®.
Power plug of wrong model	reference does not exist	Replace the power plug, see procedure D/R 003 .
CA-COM® or SpeakON® connector damaged	mechanical or electrical shock	Contact L-ACOUSTICS®.
XLR connector damaged	mechanical shock	Contact L-ACOUSTICS®.
L-NET connector damaged	mechanical shock	Contact L-ACOUSTICS®.
LCD screen, encoder wheel, key, or LED meter damaged on the DISPLAY	mechanical shock	Contact L-ACOUSTICS®.

Front panel interface		
Issue	Possible causes	Inspection procedure / Diagnosis
LCD screen switched off when the LA8 is on (“black screen”)	1. POWER CORD not connected to mains	Connect the POWER CORD to the mains.
	2. mains failure or wrong voltage	Verify if the mains is available and if the voltage is compatible with the indications on the identification plate of the controller (back panel).
	3. other cause	Contact L-ACOUSTICS®.
LCD screen lit but nothing is displayed (“blue screen”)	1. controller connected to a non-compatible network	Unplug all cables from the L-NET connectors and restart the controller.
	2. condensing humidity into the LCD screen	Put the controller in a non-condensing environment and wait until the LCD screen is dry.
	3. other cause	Contact L-ACOUSTICS®.
LCD screen lit but dark	any	Contact L-ACOUSTICS®.
Any action from the front interface has no effect (controller not in standby mode and not locked, see the LA NWM video tutorial)	any	Contact L-ACOUSTICS®.
One meter LED does not work whereas another LED of this meter works	any	Contact L-ACOUSTICS®.
The L-NET LED does not work when online (see the LA NWM video tutorial)	any	Contact L-ACOUSTICS®.

L-NET network (refer to the LA NWM video tutorial for software use)		
Issue	Possible causes	Inspection procedure / Diagnosis
Impossible to connect a controller to the L-NET network (controller not in “blue screen”)	1. offline mode selected on LA NWM	Select the online mode on LA NWM.
	2. scanning range not containing the controller IP address	Include the controller IP address in the scanning range on LA NWM.
	3. wrong IP address	Set the computer IP address and subnet mask as well as the controller IP address as indicated in the LA NWM video tutorial .
	4. L-NET cable not plugged or plugged into the wrong L-NET connector	Plug and secure a CAT5e U/FTP cable into the L-NET IN connector on the controller and the network connector on the device preceding the controller in the network chain (computer, L-NET OUT connector on another controller, or Ethernet switch). Do the same for each cable of the network chain from the controller to the computer.
	5. L-NET cable incorrectly plugged	Unplug the CAT5e U/FTP cable and plug it again on both sides. Do the same for each cable of the network chain from the controller to the computer.
	6. L-NET cable of wrong model	Use straight-through Ethernet cables of CAT5e U/FTP category (or higher) and of 100 m/328 ft maximum length. If an Ethernet switch is used and the auto MDI/MDIX functionality is not available on it, use a crossover cable between the switch and each controller.
	7. L-NET cable damaged	Replace all damaged CAT5e U/FTP cables of the network chain from the controller to the computer.
	8. another software client is already connected to the controller	Disconnect the software client.
	9. firmware failure	Restart the controller.
	10. other cause	Contact L-ACOUSTICS®.

Error message		
Issue	Possible causes	Inspection procedure / Diagnosis
<p>“High Temperature Ch x Channel Attenuated”</p> <p>“Over Temperature Ch x Channel Muted”</p>	1. room temperature too high	Reduce the temperature using a forced ventilation system.
	2. FOAM FILTER clogged	Clean the FOAM FILTER, see procedure D/R 002 .
	3. controller not getting enough cool air	<p>Install the controller in an open area so that the front and rear panels are located at a minimum distance of 30 cm from any external object or structure.</p> <p>Do not block the front and rear ventilation grills on a controller.</p> <p>If the controller is rack-mounted:</p> <ul style="list-style-type: none"> Do not block the ventilation grills with front or back panels or doors. If not possible, use a forced ventilation system. When stacking more than one controller in a rack, mount them directly on top of each other or close any open space in the rack with blank panels.
	4. channel x resources solicited to their limits	<p>Monitor the LED meter for channel x on the controller.</p> <p>In case of persistent high level or clip, reduce the audio source output level (refer to the third party documentation) and/or the gain value on channel x.</p>
	5. loudspeaker impedance too low	<p>Verify that nothing causes a short-circuit at output x (wrong cabling scheme, damaged cable, or short-circuit in the speaker voice coil).</p> <p>Verify that the number of enclosures connected in parallel to output x is not too high.</p>
	6. other cause	Contact L-ACOUSTICS®.

continued on next page...

Error message (continued)		
Issue	Possible causes	Inspection procedure / Diagnosis
“System Message Fuseprotect” and signal attenuated	controller resources solicited to their limits	Monitor the LED meters on the controller. In case of persistent high level or clip, reduce the gain values of channels OUT1-4 on the controller and the output gain value on the audio source (refer to the third party documentation).
“System Message Fuseprotect” and signal muted	mains voltage drop when the controller is on	Verify if each controller is connected to mains with the following ratings: 16 A for 230 V or 30 A for 120 V (LA8, LA8CN or LA8US), 15 A for 200 V or 30 A for 100 V (LA8JP).
“DC on Channel x Channel Muted”	sporadic DC presence	Lower the gain on channel x. If the issue persists, inspect the audio source.
“DC on Channel x Channel Disabled”	1. persistent DC presence	Inspect the audio source and restart the controller.
	2. other cause	Contact L-ACOUSTICS®.
“Error on Channel x Channel Muted”	short-circuit in loudspeaker or loudspeaker cable	Verify that nothing causes a short-circuit at the controller outputs (wrong cabling scheme, damaged cable, or short-circuit in the speaker voice coil). Then restart the controller.
“Error on Channel x Channel Disabled”	1. sporadic error	Restart the controller.
	2. other cause	Contact L-ACOUSTICS®.
“System Message Waiting SMPS”	1. controller powered off	Power the controller on.
	2. controller power supply failure	Wait for 1 minute. If the issue persists, restart the controller.
	3. mains failure or wrong voltage	Verify if the mains works and if the voltage is compatible with the indications written on the back panel of the controller.
	4. other cause	Contact L-ACOUSTICS®.
“System Message Waiting SMPS” for 1 minute, then: “System Message SMPS ERROR”	any	Contact L-ACOUSTICS®.
“System Message Update error”	1. firmware update failure	Restart the controller. If the issue persists, verify that each L-NET cable works and is correctly plugged on both ends, download firmware again and re-launch the update process.
	2. other cause	Contact L-ACOUSTICS®.
“System Message DSP ERROR”	any	Restart the controller. If the issue persists, contact L-ACOUSTICS®.
“System Message INIT ERROR”	any	Contact L-ACOUSTICS®.

continued on next page...

Error message (continued)		
Issue	Possible causes	Inspection procedure / Diagnosis
“Invalid MAC address Contact L-Acoustics”	controller may have a non-unique MAC address	Contact L-ACOUSTICS®.
“System Message Invalid L-NET Client”	controller is connected to a non-compatible version of LA-NWM	Update LA NWM to version 2.2.0.0 or above. Refer to the LA NWM video tutorial .

Sound		
Issue	Possible causes	Inspection procedure / Diagnosis
No sound and no error message (controller not in standby mode, refer to the LA NWM video tutorial)	1. outputs muted	Unmute the outputs.
	2. wrong input mode	If the fallback mode is ON, switch it OFF. Select the input mode according to the audio source format (analog or AES/EBU).
	3. wrong preset selection	Select a preset in accordance with the loudspeaker system connected to the outputs.
	4. gain value too low on the controller	Set an appropriate gain value on channels OUT1 to OUT4. If the AES/EBU input mode is selected, set an appropriate AES/EBU input gain value.
	5. audio source not plugged or plugged into the wrong input connector	Plug and secure each XLR cable into the audio source and the corresponding input connector on the controller: <ul style="list-style-type: none"> • Analog input connector for an analog audio source. • AES/EBU input connector for AES/EBU audio source.
	6. audio source cable incorrectly plugged	Unplug the XLR cable and plug it again on the audio source and the controller.
	7. audio source cable damaged	Replace the XLR cable.
	8. wrong settings on the audio source	Set appropriate parameter values on the audio source, in particular the output gain value (refer to the third party documentation).
	9. non-audio bit stream	Verify that the AES/EBU source does not deliver non-audio bit stream (e.g. encoded audio).
	10. audio source failure	Inspect the audio source for failure. <u>Reminder:</u> A digital audio source can meet the following failures: no clock, loss of lock, invalid audio (validity bit), CRC error, bipolar encoding error, data slip.
	11. loudspeaker not plugged or plugged into the wrong output connector	Plug and secure each PA-COM® or SpeakON® cable into the loudspeaker and the corresponding output connector on the controller.
	12. loudspeaker cable incorrectly plugged	Unplug the PA-COM® or SpeakON® cable and plug it again on the audio source and controller.
	13. loudspeaker cable damaged	Replace the PA-COM® or SpeakON® cable.
	14. loudspeaker damaged	<i>If only one loudspeaker is connected, inspect it. Otherwise, go to next step.</i>
	15. mains failure	Inspect the mains.
	16. other cause	Contact L-ACOUSTICS®.

continued on next page...

Sound (continued)		
Issue	Possible causes	Inspection procedure / Diagnosis
Noise Level loss Distorted sound	1. gain value too high on the controller	Set an appropriate gain value on channels OUT1 to OUT4. If the AES/EBU input mode is selected, set an appropriate AES/EBU input gain value.
	2. output gain value too high on the audio source	Set an appropriate output gain value on the audio source (refer to the third party documentation).
	3. switch to the analog fallback mode with wrong AES/EBU input gain value	Set an appropriate AES/EBU input gain value and inspect the digital audio source for failure. Reminder: A digital audio source can meet the following failures: no clock, loss of lock, invalid audio (validity bit), CRC error, bipolar encoding error, data slip. A validity bit at non-audio value will not trigger the automatic fallback. Instead the signal will be muted.
	4. wrong preset selection	Select a preset in accordance with the loudspeaker system connected to the outputs.
	5. audio source cable incorrectly plugged	Unplug the XLR cable and plug it again on the audio source and the controller. Verify with your installer if ground loops can occur.
	6. audio source cable damaged	Replace the XLR cable.
	7. wrong settings on the audio source	Set appropriate parameter values on the audio source (refer to the third party documentation).
	8. audio source failure	Inspect the audio source for failure.
	9. loudspeaker plugged into the wrong output connector	Plug and secure each PA-COM® or SpeakON® cable into the loudspeaker and the corresponding output connector on the controller.
	10. loudspeaker cable incorrectly plugged	Unplug the PA-COM® or SpeakON® cable and plug it again on the audio source and the controller. Verify with your installer if ground loops can occur.
	11. loudspeaker cable damaged	Replace the PA-COM® or SpeakON® cable.
	12. loudspeaker damaged	<i>If only one loudspeaker is connected, inspect it. Otherwise, go to next step.</i>
	13. mains failure	Inspect the mains.
	14. other cause	Contact L-ACOUSTICS®.

Exploded view

The following exploded view represents the MODULES of the LA8.

Each MODULE is indicated by a circled number. The box next to a circle indicates the **disassembly/reassembly procedure (D/R)** associated to the MODULE.

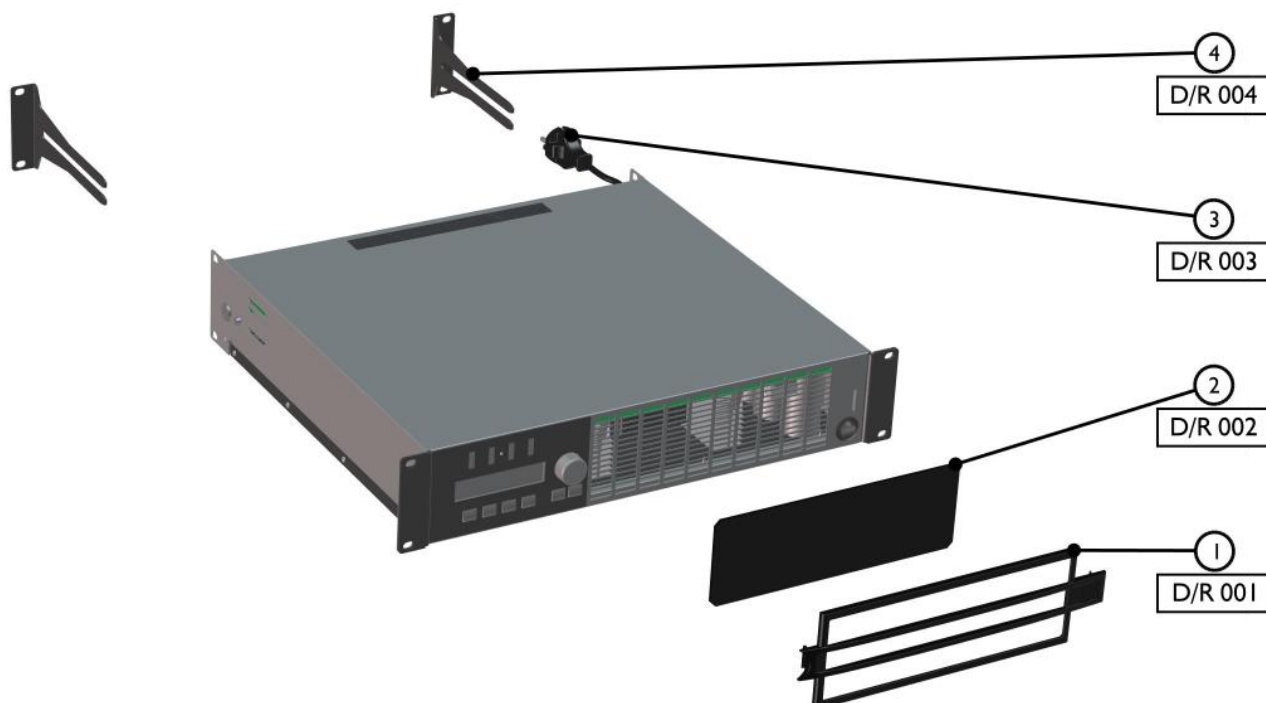

N°	MODULE name
1	FRONT FRAME
2	FOAM FILTER
3	power plug
4	REAR BRACKETS

Working time

Procedure	Working time (mn)
D/R 001	1
D/R 002	1
D/R 003	5
D/R 004	1

4 MAINTENANCE PROCEDURES

D/R 001 – FRONT FRAME

Spare parts

KR LAXGRI

N°	Description	Qty
1	frame	1

Replacement procedure

This procedure describes how to replace the FRONT FRAME on an LA8 amplified controller.

1. Pull the FRONT FRAME at one side and remove it from the controller.
2. Insert the two sides of a FRONT FRAME into the holes on the controller without locking.
Place the logo on the right.
3. Place the FOAM FILTER between the FRONT FRAME and the controller.
4. Push the FRONT FRAME on both sides until it is fully inserted.
A click must be heard on each side.

D/R 002 – FOAM FILTER

Spare parts

KR LAXMOU

N°	Description	Qty
1	foam filter	1

Cleaning or replacement procedure

This procedure describes how to clean or replace the FOAM FILTER of an LA8 amplified controller.

1. Pull on a FRONT FRAME side without removing it from the controller.
2. Do the same on the other side.
3. Remove the FOAM FILTER.
4. If the FOAM FILTER is intended to be cleaned, use mild dishwashing detergent or soap and then dry it.
5. Place a FOAM FILTER between the FRONT FRAME and the controller.
6. Push the FRONT FRAME on both sides until it is fully inserted.
A click must be heard on each side.

D/R 003 – Power plug

Tools



Name	Reference	Distributor
wire stripping pliers	793936	Facom
Stanley knife	0-10-018	Stanley
screwdriver adapted to the new power plug	—	—
voltage absence tester	—	—

Spare parts

N°	Description	Qty
1	power plug	1

Safety



There is a risk of electrical injury when the high-voltage capacitors are charged.

Before any maintenance operation, disconnect the controller from mains and wait for **10 minutes** so the capacitors discharge completely.

Check that there is no voltage at the two pins of the power plug.

Replacement procedure

This procedure describes how to replace the power plug of an LA8 amplified controller.

1. Unplug the POWER CORD from the mains and wait for **10 minutes**.
2. Check that there is no voltage at the two pins of the power plug.
Use the voltage absence tester.
3. Cut the POWER CORD near the plug.
Use the Stanley knife.
4. Strip the three wires of the power cord on a length compatible with the new plug.
Use the Stanley knife and the wire stripping pliers.
5. Fix the three wires on the new plug according to the color code of Table 1.
Use the screwdriver.

Table 1: Wire color code

Controller	Live	Neutral	Ground
LA8	Brown	Blue	Green / Yellow
LA8CN			
LA8JP			
LA8US	Black	White	Green

D/R 004 – REAR BRACKETS

Spare parts

KR LABRACKET

N°	Description	Qty
1	bracket	2

Replacement procedure

This procedure describes how to replace the REAR BRACKETS of an LA8 amplified controller.

1. Remove the two old REAR BRACKETS from the amplified controller pulling on them, see Figure 1.

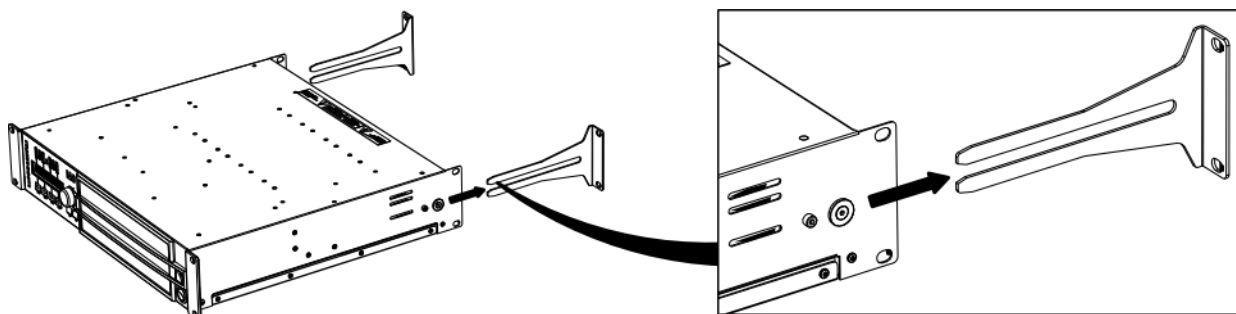

Figure 1: Removing the REAR BRACKETS

2. Insert the two new REAR BRACKETS pushing on them until they are locked.

APPENDIX: KR LIST

Reference	Concerned MODULE	KR contents	Associated procedure
KR LABRACKET	REAR BRACKETS	2 brackets	D/R 004
KR LAXGRI	FRONT FRAME	1 frame	D/R 001
KR LAXMOU	FOAM FILTER	10 foam filters	D/R 002



Document reference: LA8_MMI_EN_2.0

Distribution date: June 10, 2014

© 2014 L-ACOUSTICS®. All rights reserved. No part of this publication may be reproduced or transmitted in any form or by any means without the express written consent of the publisher.